

# HY series HY03801 (230V) & HY03803 (230/400V)

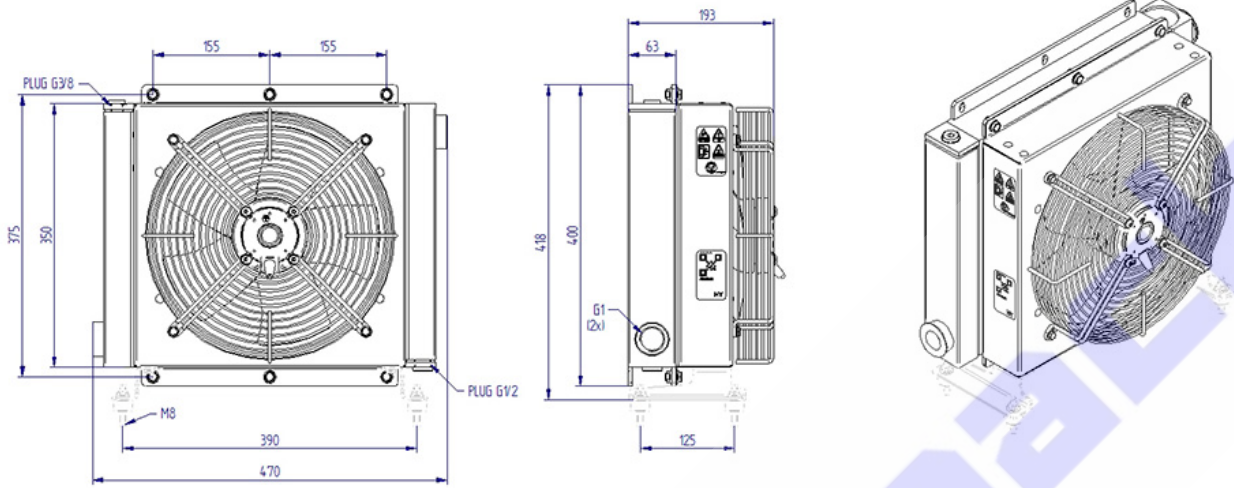

## Technical data

Item	Oil flow [l/min]	Capacity [l]	Weight [kg]	Rpm	Voltage [V]	Frequency [Hz]	Current absorption [A]	Power [W]	Ø Fan [mm]	Air flow [m³/h]	Noise level [db(A)]
<b>HY03801</b>	20-140	2,5	14,5		230	50/60	1,20	280	300	2160	73
<b>HY03803</b>	20-140	2,5	14,5		230/400	50/60	0,36	210	300	2150	72

## Performance

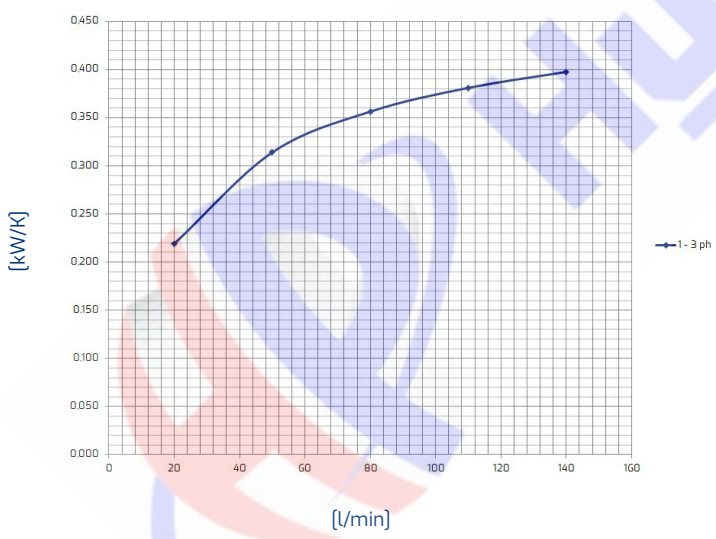

Oil T 80°C  
T Amb. 40°C

## Pressure drop

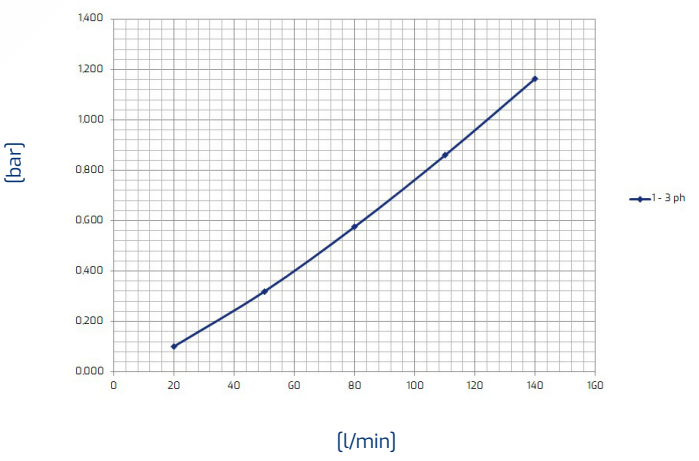

Viscosity - ISO VG 32 Oil					
Oil	22	32	46	68	150
Correction factor	0,8	1	1,2	1,6	3